



PlastiSpan™ Insulation

Wall Applications

Selection, Application and Specification

This brochure provides design notes, application instructions and specifications applicable to PlastiSpan building insulation for wall applications. The required installation method varies dependent upon the membrane to be applied above the

insulation. The selection chart below indicates additional brochures, which should be reviewed for complete information on the use of PlastiSpan insulation for wall applications.

Exterior Insulating Sheathing

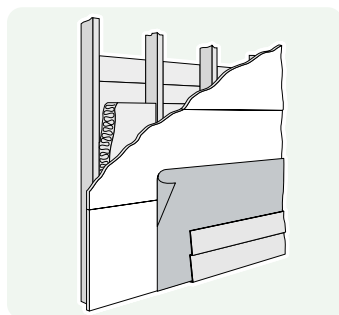

- Wood or steel stud framing
- Monolithic insulation layer on exterior
- Increased effective thermal resistance
- Familiar framing

Commercial / Industrial Applications

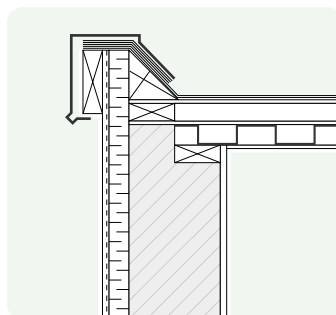

- Can be constructed in cold weather
- Provides a fully insulated wall.

Exterior Insulation Finish Systems

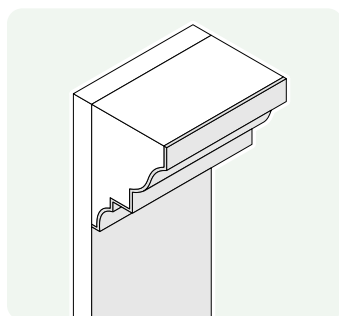

- Eliminates rain penetration.
- Fully insulated wall.

Rain Screen (Cavity) Walls

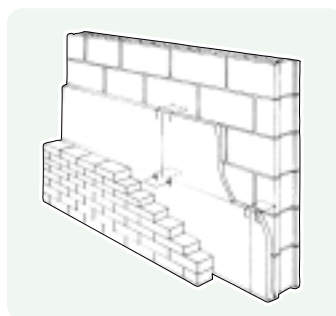

- Eliminates rain penetration.
- Fully insulated wall.

Interior Systems

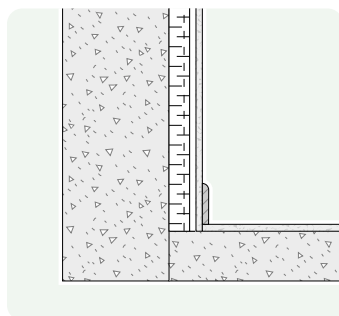

- Used for Commercial or Residential applications.
- Resists moisture.
- Fast and simple installation.

Precast Concrete Panels

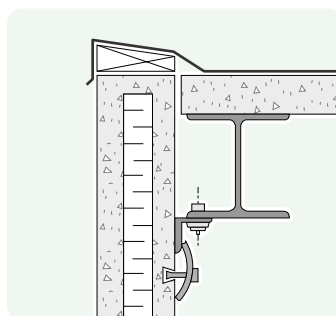

- Fast construction.
- Permanently insulated.
- Component in precast sandwich panels or interior surface of precast wall.

Design Notes

PlastiSpan insulation board is a rigid expanded polystyrene (EPS) product. The closed cell structure of PlastiSpan insulation does not contain CFC's, HCFC's or HFC's, which assures long lasting thermal insulation properties. It is chemically inert to a wide range of chemicals; it has no food value and it provides no nourishment for insects, parasites, animals or plant life.

PlastiSpan insulation is incorporated into walls, floors and/or ceilings above grade in order to reduce the energy loss through the design of the structure.

In many buildings, above-grade walls present the greatest area through which heat may be lost or gained. Windows in walls are a major cause of heat loss. Double or triple glazed windows should be considered along with adequate wall insulation. General ceiling insulation is installed in the same manner as wall insulation.

Floors are not usually large contributors to heat loss but in cases where the building is stepped back or cantilevered, floors must be insulated. Where structural floor insulation is required, see Plasti-Fab brochure on split slab design. For slab-on-grade concrete floors see Plasti-Fab brochure for floor insulation or radiant floor heating systems.

Building Codes require minimum thermal resistance for various types of construction in different geographical areas. (See applicable Building Code in your region.) As well, model energy codes, such as the Model National Energy Code (MNEC) for Buildings and Houses were prepared by the Canadian Commission on Building and Fire Codes (CCBFC) and published by the National Research Council (NRC). Since, under the Constitution Act, regulation of building in Canada is the responsibility of provincial and territorial governments, the MNECB and MNECH were prepared in the form of model codes to permit adoption by the appropriate authority.

The MNECB and MNECH differ from model codes traditionally produced by CCBFC in that they address environmental protection and resource conservation issues rather than the health and safety of occupants. They are essentially a set of minimum requirements for energy efficiency in buildings. These requirements are, for the most part, based on extensive cost-benefit analysis that take into consideration climate, fuel types and costs, and construction costs. They establish a standard of construction for those features of buildings, which affect their energy efficiency.

National Building Code

PlastiSpan insulation is a combustible material that is permitted for use in either combustible or non-combustible construction. CAN/ULC-S701 requires PlastiSpan insulation, as delivered to the Customer, shall be suitably marked to identify its type number, the ULC Standard number, and the manufacturer's name or trademark. The product shall also be marked with a warning: "CAUTION: THIS PRODUCT IS COMBUSTIBLE. A PROTECTIVE

BARRIER OR THERMAL BARRIER IS REQUIRED AS SPECIFIED IN THE APPROPRIATE BUILDING CODE".

The insulation may be held in place by the system itself, by adhesives, or by various mechanical fastening systems. Since the building code requires interior finishes over the insulation to be fastened to the supporting assembly, adhesives are only used to maintain the insulation in place until devices are in place to support the finish. Exterior finishes may be supported by the insulation.

Air Barriers

It is important that the wall design provide an air barrier over the total wall system with particular attention being paid to intersection of the wall with structural members, windows, electrical components, etc. The air barrier system must be capable of minimizing the effect of any post construction cracks, shrinkage, and building movement.

Thermal Resistance

The thickness of the insulation required will depend to some extent on the comfort factor required in the structure. The main criteria for thickness will be a cost/benefit analysis designed to balance the capital cost of the insulation against the saving in energy costs over the life of the building and to meet minimum thermal resistance required in the Building Code.

Adhesives

The adhesive serves to bond the insulation in place on the wall or ceiling. Some adhesive types may also be used to provide an air or vapour barrier for the wall system. Adhesive used in contact with PlastiSpan insulation must be recommended for use with expanded polystyrene insulation by the adhesive manufacturer and applied in accordance with the adhesive manufacturer's instructions.

T-stud

This electro-galvanized rolled section has been developed to allow PlastiSpan insulation to be fastened to a masonry or concrete wall and to provide a flange on the surface of the insulation for fastening the wall finish such as gypsum board using a drive screw. This meets the requirements of the National Building Code.

It provides an extremely fast and economical method for erecting and fastening PlastiSpan insulation to concrete or masonry walls. Unlike adhesive methods, installation is unaffected by weather or temperature and the system permits the almost simultaneous installation of both the insulating and finish materials without extensive wall preparation. The system allows for the complete coverage of the wall with insulation.

Fasteners

A number of patented fasteners can be used to fasten T-stud, Z-bars or nailers to a concrete or concrete block wall. When a fastener is used to hold the insulation in place it is used with a 25.4 mm (1") pre-punched fibre washer under the head to provide a larger bearing surface for the fastener .

Design Notes

Gripcon® Fasteners

These types of fasteners are designed to fasten a nailer, strap, bracket, etc. onto concrete or masonry walls. A close tolerance carbide drill bit is used with a hammer drill to make a pilot hole

into the concrete or masonry. The Gripcon fastener is driven into the pilot hole with a hammer to provide quick and easy attachment. Minimum embedment of 25.4 mm (1") is recommended.

General Application Instructions

Preparation Requirements - Concrete, Precast Concrete Walls

Surfaces to be level, straight and clean. Remove fins or projections left after stripping concrete forms. If surfaces are not straight make good with mortar.

Floors

Straight and level with a wood float surface.

Masonry

Surfaces are plumb and straight with mortar joints cut flush with masonry.

Steel

Profiles and structural members securely fastened to the structure.

Application Instructions

The application of PlastiSpan insulation will vary depending on the wall substrate, the system and the finish to be applied. System specific applications are listed in the following PlastiSpan Building Insulation Wall Application brochures; Commercial / Industrial Construction, Exterior Insulation Finish Systems, Exterior Insulation Sheathing - New or Retrofit Construction, Interior Systems, PlastiSpan M Insulation, Precast Concrete Wall Panels and Rain Screen (Cavity) Walls.

Walls and Floors

Check that surfaces are clean and dry. If adhesives are to be used ensure surface is free of frost and that temperature of wall is suitable for the adhesive.

Insulation

Lay boards in parallel course, joints tightly butted. Butt insulation board tight against adjacent structural members or surfaces.

For adhesive application (air or vapour barrier).

Apply 3 mm (1/8") thick continuous film and press insulation into adhesive while tacky;

OR

Apply 25 mm (1") spots of adhesive to insulation board at 200 mm (8") o.c. and press insulation into place with a slight sliding motion. Coat surface of insulation joints with adhesive;

OR

Apply adhesive to wall with notched trowel 12 mm x 12 mm x 89 mm o.c. (1/2" x 1/2" x 3-1/2") and press insulation into adhesive with a sliding motion while the adhesive is still tacky. Coat surface of insulation joints with adhesive.

For adhesive application (air or vapour barrier not necessary).

Apply 25 mm (1") spots of adhesive to insulation board 200 mm (8") o.c. as above - joints of insulation need not be coated;

OR

Apply adhesive to wall with notched trowel as above - joints of insulation need not be coated.

Where adhesive fastening is necessary for temporary placement of insulation.

Use 25 mm (1") spots of adhesive where necessary to place insulation board until finish or air/vapour barrier can be applied.

T-Stud Application

Erect PlastiSpan Insulation Boards with long dimension vertical on walls up to 2400 mm (8'-0"), horizontal on higher walls, or as required by the finish.

Butt edges of boards tightly to T-Stud and adjacent boards to permit maintenance of T-Stud centres at 600 mm (24"). Insert T-Stud into insulation joint recess. Secure through insulation to wall as detailed, with mechanical fasteners through pre-drilled holes at maximum 750 mm (30") centres, with at least 4 fasteners per 2350 mm (7'-10").

Erect insulation boards on ceiling in similar manner. Install insulation boards at wall/floor and wall/ceiling junctures as detailed using angle track where necessary to provide attachment for finish.

Air / Vapour Barrier

Mechanically fasten air vapour barrier to wall (nailer) (stud) using suitable fasteners;

OR

Use 25 mm (1") spots of adhesive to place barrier until finish can be applied. Joints on barrier to be lapped and sealed where necessary.

Steel

Profiles and structural members securely fastened to the structure.

Specification

This specification consolidates essential information about Plasti-Fab PlastiSpan insulation in a 10-part specification that conforms to the editorial style of Construction Specifications Canada.

1. General

Product Name

PlastiSpan Insulation Board

Product Type

Moulded expanded polystyrene (EPS) insulation.

2. Manufacturer

Plasti-Fab Ltd.

Contact Information:

Toll-free Number: 1-888-446-5377

E-mail: mailbox@plastifab.com

Website: www.plastifab.com

3. Product Description

Description

PlastiSpan insulation is a rigid insulation board that does not contain any HFCs or HCFCs.

Basic Use

PlastiSpan insulation board provides a continuous thermal blanket that eliminates thermal bridges. The closed cellular structure of PlastiSpan insulation board provides excellent resistance to moisture and is ideal for all uses above and below grade. It may be used as exterior wall sheathing and on the interior or exterior of foundation walls to provide a monolithic thermal blanket that eliminates thermal shorts. When used on the exterior of the foundation wall, it will keep the cold away from the foundation, will act as a drainage plane and will protect the foundation dampproofing during backfilling. Placing PlastiSpan insulation board above or below floor slabs will provide a monolithic layer that resists moisture and provides a warmer floor.

Composition and Materials

PlastiSpan insulation is inert, non-nutritive and highly stable, and will not decompose, decay or produce undesirable gases or leachates. It is lightweight, rigid and easy to handle, and the closed-cell structure assures long lasting thermal insulation properties and resistance to absorption of moisture.

Insulation Board Sizes

Typical board sizes are: 1220 mm x 2440 mm (48" x 96") and 610 mm x 2440 mm (24" x 96"). However, other sizes requested by customer can be accommodated by Plasti-Fab.

Limitations

- Rigid foamed plastic insulation products, such as PlastiSpan insulation, are combustible. Although product contains a combustion modifier to inhibit accidental ignition, the product should not be exposed to a large, continuous fire source.
- The continuous service temperature limit of PlastiSpan insulation is 70°C (160°F). Constant exposure to temperatures above 70°C (160°F) will shrink and warp the product.
- Petroleum products will cause EPS insulation to soften and collapse. Attention must be given to the selection of adhesives, coatings and separation sheets to ensure compatibility with EPS insulation.
- Insulation must be protected from extended periods of exposure to direct sunlight by covering with a tarpaulin or opaque, light-coloured polyethylene film.

4. Technical Data

Applicable Standards

ASTM International (ASTM)

- ASTM C 177-97, Standard Test Method for Steady-State Heat Flux Measurements and Thermal Transmission Properties by Means of the Guarded-Hot-Plate Apparatus.
- ASTM C 203-99, Standard Test Method for Breaking Load and Flexural Properties of Block-Type Thermal Insulation.
- ASTM C 518-98, Standard Test Method for Steady-State Thermal Transmission Properties by Means of the Heat Flow Meter Apparatus.
- ASTM C 578-01, Standard Specification for Rigid, Cellular Polystyrene Thermal Insulation.
- ASTM D 1621-00, Standard Test Method for Compressive Properties of Rigid Cellular Plastics.
- ASTM D 2126-99, Standard Test Method for Response of Rigid Cellular Plastics to Thermal and Humid Aging.
- ASTM D 2842-01, Standard Test Method for Water Absorption of Rigid Cellular Plastics.
- ASTM D 2863-00, Standard Test Method for Measuring the Minimum Oxygen Concentration to Support Candle-Like Combustion of Plastics (Oxygen Index).
- ASTM E 84-01, Standard Test Method for Surface Burning Characteristics of Building Materials.
- ASTM E 96-00e1, Standard Test Methods for Water Vapor Transmission of Materials.

Specification

Canadian General Standards Board (CGSB)

- CAN/CGSB-51.32-M77, Sheathing, Membrane, Breather Type.
- CGSB 71-GP-24M, Adhesive, Flexible, for Bonding Cellular Polystyrene Insulation.

National Research Council (NRC)

- CCMC #12424-L, PlastiSpan/PlastiSpan Type 1 / PlastiSpan EFS.
- CCMC #12425-L, PlastiSpan HD/PlastiSpan HD Type 2 / PlastiSpan M24.
- CCMC #12426-L, PlastiSpan Type 3 / PlastiSpan M28.

Underwriters' Laboratories of Canada (ULC)

- CAN/ULC-S102.2, Standard Method of Test for Surface Burning Characteristics of Flooring, Floor Covering and Miscellaneous Materials.
- CAN/ULC-S107, Fire Tests of Roof Coverings.
- CAN/ULC-S701, Standard for Thermal Insulation, Polystyrene, Boards and Pipe Covering.
- ULC List of Equipment and Materials, March 2000.

Environmental Considerations

- Energy consumption associated with HVAC operations will be reduced through use of insulation with high thermal efficiency.
- PlastiSpan insulation board does not contain a captive blowing agent such as a CFC, HFC or HCFC to enhance R-Value so it is not subject to thermal drift and will maintain a constant R-value over time.
- PlastiSpan insulation will not produce any undesirable gases or leachates, and is recyclable where facilities exist.

Physical/Chemical Properties

Thermal resistance values given below are for a material thickness of 25 mm (1").

- Thermal resistance @ 24 °C (75 °F) mean temperature (to ASTM C 177 or ASTM C518):
 - Type 1:
0.65 m² • °C/W • 25 mm (3.75 ft² • hr • °F/BTU • in).
 - Type 2:
0.70 m² • °C/W • 25 mm (4.04 ft² • hr • °F/BTU • in).
 - Type 3:
0.74 m² • °C/W • 25 mm (4.27 ft² • hr • °F/BTU • in).
- Compressive strength @ 10% deformation (to ASTM D 1621 – Procedure A):
 - Type 1: 70 kPa (10 psi).
 - Type 2: 110 kPa (16 psi).
 - Type 3: 140 kPa (20 psi).

- Flexural strength (to ASTM C 203 – Procedure B):
 - Type 1: 170 kPa (25 psi).
 - Type 2: 240 kPa (35 psi).
 - Type 3: 300 kPa (44 psi).
- Water vapour permeance (to ASTM E 96):
 - Type 1: 300 ng/Pa • s • m² (5.2 perms).
 - Type 2: 200 ng/Pa • s • m² (3.5 perms).
 - Type 3: 130 ng/Pa • s • m² (2.3 perms).
- Water absorption (to ASTM D 2842):
 - Type 1: 6% by volume.
 - Type 2: 4% by volume.
 - Type 3: 2% by volume.
- Dimensional stability – 7 days @ 21°C (71.6°F) ± 2°C (1.8°F) (to ASTM D 2126):
 - Types 1, 2 and 3: 1.5% linear change.
- Compressive modulus (to ASTM D 1621 – Procedure A):
 - Type 1: 2375 kPa (344 psi).
 - Type 2: 4900 kPa (710 psi).
 - Type 3: 7100 kPa (1030 psi).
- Limiting oxygen index (to ASTM D 2863):
 - Types 1, 2 and 3: 24%.
- Flame Spread (to CAN/ULC-S102.2): 290.
- Smoke developed (to CAN/ULC-S102.2):
>500 for thicknesses from 25 to 100 mm (1" to 4").

5. Installation

Preparatory Work

Handle, store and protect boards in accordance with Plasti-Fab recommendations. Ensure product is protected from direct sunlight with tarpaulins or light-coloured polyethylene sheets, and secure against movement from wind storms at the storage location. Handle boards carefully so corners are not broken off or otherwise damaged.

Methods of Application

Installation methods may vary with specific applications. Instructions for all applications can be found in various Plasti-Fab brochures, in the full version of the applicable Masterformat Specification or on the Plasti-Fab website at www.plastifab.com.

General Application Instructions

Precautions

- Rigid foamed plastic insulation, such as PlastiSpan insulation, is combustible and should be treated with normal care accorded to all combustible materials. Although EPS insulation contains a combustion modifier to inhibit accidental ignition, the product should not be exposed to a large, continuous fire source. Avoid open flames, welding torches and high intensity lamps, and if welding is necessary in proximity to the EPS insulation, protect the insulation with fire-rated gypsum board or similar products.
- Do not leave plastic foam insulation exposed in inhabited areas. A protective barrier or thermal barrier is required as specified in the appropriate Building Code.

Building Codes

Installation must comply with all applicable local, provincial and National code jurisdictions. Plasti-Fab can offer technical assistance as needed.

6. Availability and Cost

Availability

Plasti-Fab Ltd. is headquartered in Calgary, Alberta, Canada and has been serving customers in Canada and the US for over 30 years. Contact Plasti-Fab using any of the methods listed in Part 2 of this specification for current list of facilities and agents.

Cost

Contact Plasti-Fab using any of the methods listed in Part 2 of this specification for current pricing information. Cost information may also be obtained from a local Plasti-Fab dealer.

7. Warranty

It is the responsibility of the contractor to install PlastiSpan insulation board in accordance with Plasti-Fab Ltd. published recommendations. Plasti-Fab assumes no liability resulting from a failure to follow these instructions. Plasti-Fab offers a warranty for RSI value (R-value) retention over time. Plasti-Fab's liability is expressly limited to replacement of defective goods. Any claim shall be deemed waived unless made in writing to Plasti-Fab within 30 days from the date it was, or reasonably should have been, discovered. Further information on warranty conditions, duration and remedies may be obtained from Plasti-Fab.

8. Maintenance

PlastiSpan insulation products are maintenance free when installed according to Plasti-Fab's published recommendations.

9. Technical Services

Plasti-Fab's broad distribution network ensures exceptional customer service. One of the most comprehensive design manuals in the industry is available to assist engineers, architects and specification writers to determine how to make the best use of EPS. For more information, contact Plasti-Fab using any of the methods listed in Part 2 of this specification.

10. Filing Systems

Additional product information is available upon request from Plasti-Fab.